

# Theatre Stage

NRO604



Item no. NRO604-0621

## General Product Information

Dimensions LxWxH	277x147x168 cm
Age group	1+
Play capacity (users)	6
Colour options	



The Robinia Theatre Stage holds an eternal attraction to children: they love to perform and meet. With its red curtain detail and megaphone, the stage will repeatedly be used by the children in dramatic and social play scenarios. Performing on the Robinia stage trains important life skills such as self-awareness, self-control and cooperation. The

dramatic play is a favorite play type of preschoolers, and stimulates language development. The elevated platform of the stage invites socializing and is used as a place for a break, too. Children also use the stage for jumping on and off, building bone density and muscle strength as they do so. The curtains are made from tactile, flexible rubber. The

megaphone makes it possible to announce new shows. The distortion of the voice in the megaphone additionally trains the child's understanding of cause-and-effect.



Data is subject to change without prior notice.

# Theatre Stage

NRO604



All Organic Robinia products by KOMPAN are made of 100% Robinia wood from sustainable European sources. On request it can be supplied with FSC® Certified (FSC® C004450) Robinia wood.



The paint used for coloured components is water based environmental friendly with excellent UV resistance. The paint is in compliance with EN 71 Part 3.



Play activities in very strong materials: HDPE-plate with HDPE-clock and hands in conveyer belt rubber, bell in pressed aluminium. Mirror in plexi-glass with a high impact resistant.

Item no. NRO604-0621

### Installation Information

Max. fall height	0 cm
Safety surfacing area	22,2 m <sup>2</sup>
Number of installers	2
Total installation time	7.8
Excavation volume	0,45 m <sup>3</sup>
Concrete volume	0,00 m <sup>3</sup>
Footing depth (standard)	60 cm
Shipment weight	301 kg
Anchoring options	In-ground ✓

### Warranty Information

Robinia wood	15 years
Stainless steel components	Lifetime
Stainless steel components	Lifetime
Spare parts guaranteed	10 years



All rubber activities/components are made of conveyer belt rubber that makes it extremely weather resistant and long lasting.



The percussion panel consist of 2 Conga Drums with PP tubes and top in coloured ABS. Babel drum in stainless steel 316L.

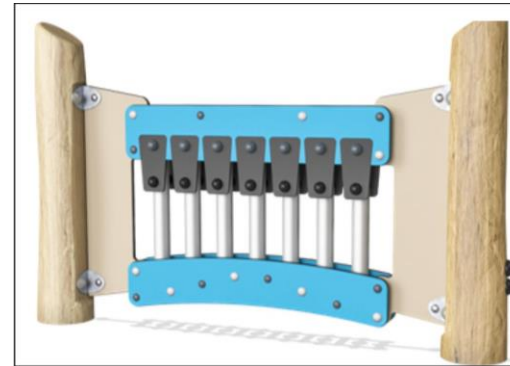

The Xylofon music panel consist of HDPE - material in 19mm EcoCore™. EcoCore™ is a highly durable, ecofriendly material. The pipes are made of die-cast aluminium specifically alloyed for outdoor environments.



# Theatre Stage

NRO604

\* Max fall height | \*\* Total height | \*\*\* Safety surfacing area

\* Max fall height | \*\* Total height

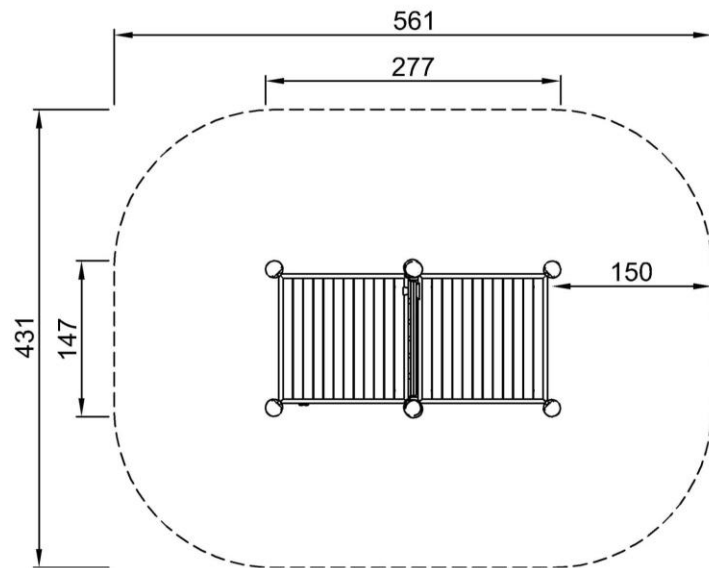

NRO604  
\*\*168cm  
\*\*\*22.2m<sup>2</sup>

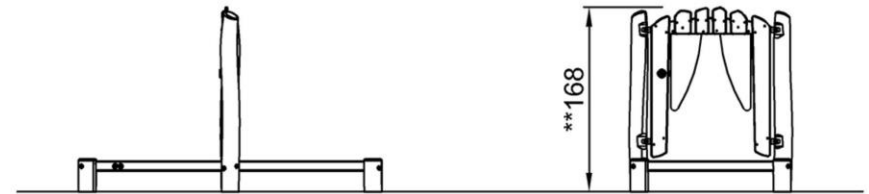

NRO604  
1:100

[Click to see 1:100 ratio TOP VIEW](#)

[Click to see 1:100 ratio SIDE VIEW](#)

# Theatre Stage

NRO604



## Low curtains

**Physical:** tactile stimulation supports sensory skills, when children explore the characteristics (e.g. hardness, weight) of the materials.

**Social-Emotional:** invites parallel play, having two similar curtains. The curtains set a tangible theme and thus spur dramatic play. Dramatic play is a great trainer of language skills.

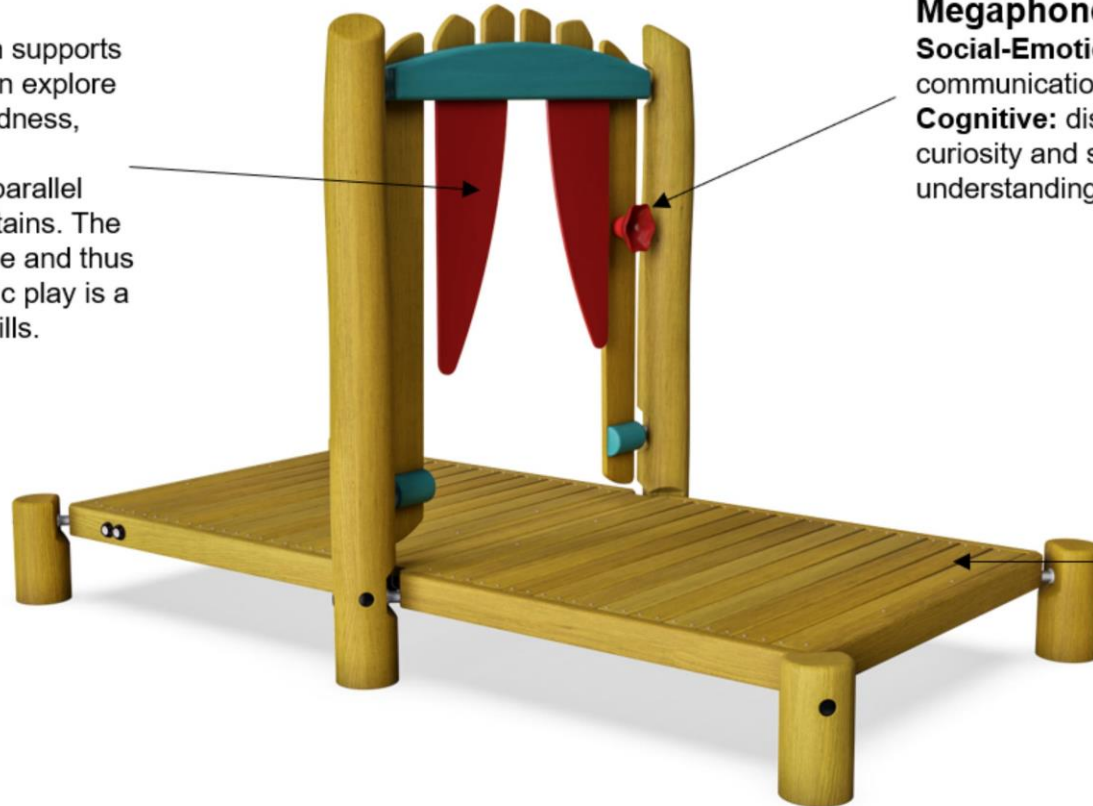

## Megaphone

**Social-Emotional:** inspires communication and turn-taking skills.  
**Cognitive:** distortion of sound evokes curiosity and stimulates an understanding of cause and effect.



## Stage

**Physical:** jumping on and off stage trains muscles and builds bone density.  
**Social-Emotional:** the spacious platform invites meetings and cooperation.  
**Cognitive:** the stage setting invites dramatic play and performance, which stimulates language development.



# Theatre Stage

NRO604



**PHYSICAL**  
Joy of movement:  
motor skills, muscle, cardio  
and bone density



**SOCIAL-EMOTIONAL**  
Joy of being together:  
teamwork, tolerance and  
sense of belonging



**COGNITIVE**  
Joy of learning:  
curiosity, understanding of causal  
relationships and knowledge of the world



**CREATIVE**  
Joy of creating:  
co-creation and experimenting  
with materials



**BALANCE**  
To balance is to stay upright when walking or standing on a surface that makes this challenging (e.g. a wobbly, inclined, or narrow surface).



**HANG IN ARMS**  
To hang in arms is the act of carrying the body with the hands or arms, possibly to traverse to another platform or play item.



**SENSORY**  
To sense is the act of taking in information with the sensory system: seeing, feeling, hearing or sensing with the body.



**BOUNCE**  
To bounce is the act of bouncing on a responsive, flexible, elastic or tensile surface.



**JUMP**  
To jump is the act of jumping up or down on a hard surface.



**SLIDE**  
To slide is the act of moving fast downwards seated on a slide.



**CLIMB**  
To climb is the act of moving upwards, cross-coordinating arms and legs, on a vertical or inclined surface or net.



**PULL**  
To pull is the act of pulling an item towards you or you towards an item with one or both hands, or possibly using the entire body.



**SOCIALIZE**  
To socialize is the act of meeting, communicating or cooperating in an activity that stimulates and facilitates social interaction.



**CONSTRUCT**  
To construct is the act of creating new patterns, shifting items or materials to new positions or constructing with materials that can be transformed or manipulated.



**PUSH**  
To push is the act of pushing an item away from you with one or both hands, possibly with the entire body.



**SPIN**  
To spin involves a fast, repeated horizontal or vertical turn of the body on a piece of equipment that facilitates the movement.



**CRAWL**  
To crawl is the movement of moving forwards or backwards, cross-coordinating arms and legs, on a horizontal or slightly inclined surface.



**ROCK**  
To rock is the action of rocking back and forth, or sideways, on e.g. a piece of spring equipment.



**SWAY**  
To sway is the movement of swaying back and forth, or around, lying, seated or possibly standing, in a pendulant or circular movement, e.g. on a hammock or on a rope.



**DRAMATIC PLAY**  
Dramatic play is motivated through play items that stage a frame, place or environment for acting out make believe or role play scenarios.



**ROTATE**  
To rotate involves a vertical or horizontal slower paced turn of the body, facilitated by a piece of equipment.



**SWING**  
To swing is the movement of swinging back and forth, or in circular movement, seated, standing or lying, in an unhindered arc.



**GLIDE**  
To glide is the act of moving from one point to another without shifting the feet, in a horizontal or vertical movement, in a seated, lying or standing position, letting gravity do the work.



**RULES PLAY**  
Rules play is motivated through play items that suggest games-with-rules, cooperation and team work, e.g. tic-tac-toe, timers or ball games.



**WONDER**  
To wonder is motivated through play items that make children need and use their logical, abstract or creative thinking skills, as well as their memory.