

Vertical Net/Wall Robinia

FRO216



Item no.	
General Product Information	
Dimensions LxWxH	232x112x261 cm
Age group	13+
Capacity (users)	3
Colour options	



The wall consists of two segments. The left side is a flat wall of almost 2.40m high which can be conquered by the fittest. The right side has three steps to assist the feet and eight handles to help you get over the wall. The scalable wall makes it fun for everyone to play or train together. Everyone will develop muscle strength and bone density when jumping over

or even improve their self-esteem if they dare to climb up.

The Robinia bars are made from de-barked and sap-free Robinia trunks in various dimensions. Robinia is a native European wood species with high strength and natural durability in various climatic conditions. KOMPAN uses wood from

FSC-certified sources.



Vertical Net/Wall Robinia

FRO216

All Organic Robinia products by KOMPAN are made of 100% Robinia wood from sustainable European sources. On request it can be supplied with FSC® Certified (FSC® C004450) Robinia wood.

The Robinia wood can be supplied as untreated raw wood or painted with a brown coloured transparent pigment that maintains the golden wood colour of the wood.

All KOMPAN fitness products are compliant with the ASTM F3101 & EN16630 Outdoor Fitness Standards. Load tests are performed as a static test by adding dynamic factors as well as safety factors to the specified load of 78kg per user. A product intended for 1 user is loaded with 420kg.

The wall surface are made of 17.8mm thick High Pressure Laminate (HPL) panels to ensure optimal strength and durability.

The ropes are made of UV-stabilised PES with inner steel cable reinforcement. The rope is induction treated in order to create a strong connection between steel and rope which leads to good wear resistance.

Item no.	
Installation Information	
Max. fall height	233 cm
Safety surfacing area	19,7 m ²
Number of installers	2
Total installation time	0,0
Excavation volume	
Concrete volume	
Footing depth (standard)	
Shipment weight	
Anchoring options	
Warranty Information	
Robinia wood	15 years
Hot dip galvanised steel	Lifetime
Corocord rope	10 years
HPL panel	15 years
Spare parts guaranteed	10 years





Cradle to Gate A1-A3	Total CO ₂ emission	CO ₂ e/kg	Recycled materials
	kg CO ₂ e	kg CO ₂ e/kg	%

The overall framework applied for these factors is the Environmental Product Declaration (EPD), which quantifies "environmental information on the life cycle of a product and enable comparisons between products fulfilling the same function" (ISO, 2006). This follows the structure and applies a Life-Cycle Assessment approach to the entire Product stage from raw material through manufacturing (A1-A3))

Kompan A/S
 C.F. Tietgens Boulevard 32C
 DK-5220 Odense SØ
 Denmark



Validation of CO₂ calculation of: Fitness



Data version no. 2021-09-27

The CO₂ calculation and data are in compliance with the principles of a carbon footprint impact according to the GHG protocol (Greenhouse Gas Protocol), Scope 3, cradle to gate related to all individual components in the product category: "Fitness" represented by item no.: FAZ10100-0900 (Scope 3 emissions include emission sources in the upstream and downstream value chain).

Date: 15. October 2021 | Valid until: 15. October 2023

Validated by:

Bente Hviid, Senior Consultant

Peter Bendtsen, Senior Consultant

Validation based on report: Validation of CO₂ calculation of 8 categories of Kompan product line, version 1.0, prepared by: Bureau Veritas HSE, Denmark: Bente Hviid and Peter Bendtsen.

Publication date: 15. October 2021

By Bureau Veritas HSE
 www.bureauveritas.dk
 +45 7731 1000



Vertical Net/Wall Robinia

FRO216

* Max fall height | ** Total height | *** Safety surfacing area

* Max fall height | ** Total height

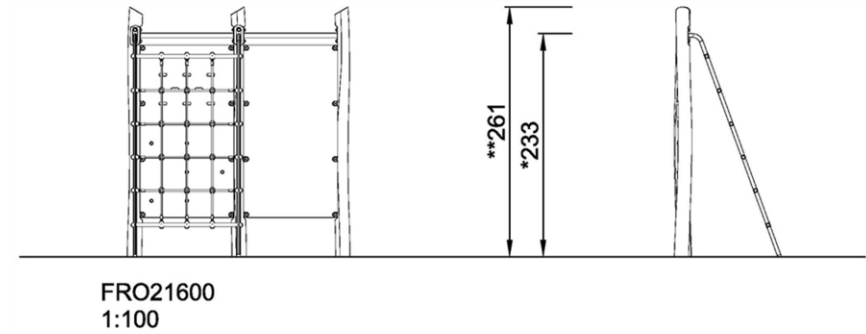
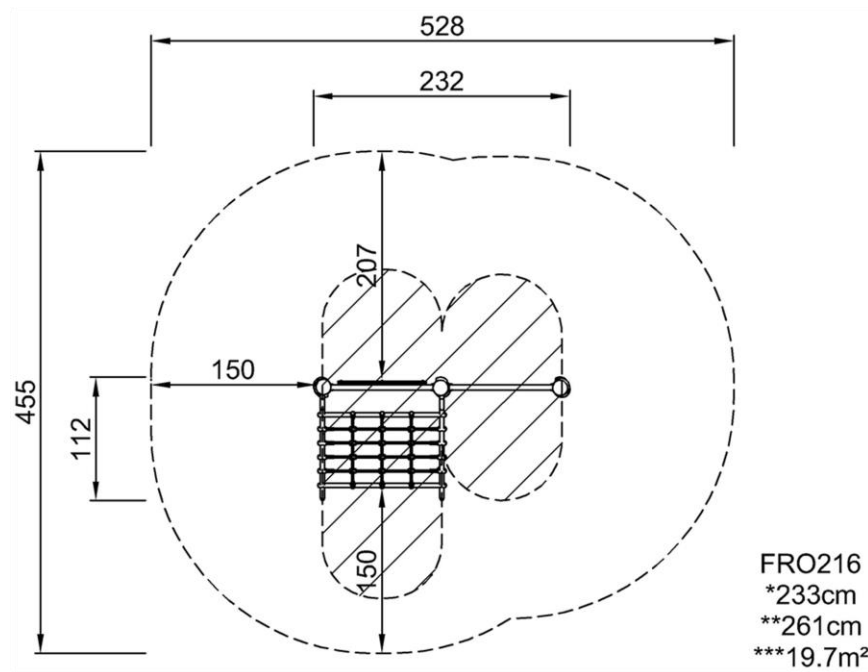

[Click to see 1:100 ratio TOP VIEW](#)

[Click to see 1:100 ratio SIDE VIEW](#)