

# Giant CocoWave Swing



M984

**KOMPAN**



Item no. M98401-1011

## General Product Information

Dimensions LxWxH	620x270x363 cm
Age group	6+
Play capacity (users)	8
Colour options	 

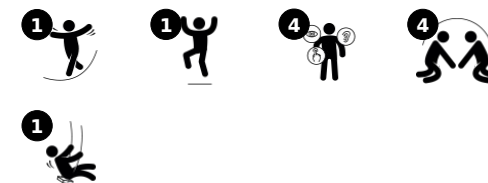

The size and appearance of the Cocowave Pendulum Swing is an irresistible invitation for all children to play. With its robust, oblong coconut rope, the Cocowave Pendulum Swing allows for swinging from a seated, lying or standing position. The thrill of swinging - mildly or wildly - is for bigger groups, of different

sizes, ages and physical abilities. It takes teamwork to make the swing move, and this stimulates important social-motional skills. Apart from being fun, swinging on the Coco-wave swing also trains muscles and important motor skills, such as balance, coordination and sense of space. These are important to train vestibular

skills that matter profoundly for e.g. navigating traffic safely. The tickling, challenging feeling of speed and height stimulates children's self-esteem, risk management and other important social-emotional life skills.



# Giant CocoWave Swing

M984



## Chains

**Physical:** space between chains supports a comfortable grip for use of muscle strength when standing up swinging.



## Cocowave swing

**Physical:** supports muscle strength, sense of balance and space. Bone density is built up when children swing and jump on-off. **Social-Emotional:** height and speed of swinging supports self-esteem. When listening and negotiating, children develop their empathy and cooperation skills. **Cognitive:** height and speed of swinging helps children to judge distances and heights.



## Coconut rope

**Physical:** balance and coordination is supported when walking the swaying rope. A good sense of balance transfers to other skills such as sitting still on a chair. Bone density is developed when jumping off. **Social-Emotional:** children swaying together on the rope experience their own and others' movements. This spurs cooperation and consideration, e.g. when passing others on the rope.



## Connectors in the side of the rope

**Physical:** allow for foot position between connectors resulting in ease of use when standing up swinging. Develops muscle strength. **Social-Emotional:** room for different body positions like standing, sitting and lying.

# Giant CocoWave Swing

M984



The steel pipes are hot dip galvanised inside and outside with lead free zinc. The galvanisation has excellent corrosion resistance in outside environments and requires low maintenance.



Powder coated top finish on top of galvanisation is processed in two steps: Light grinding and clean sweeping, powder coating - thickness 70-120 µm.



Unique designed swing hangers of stainless steel with anti-twist function. The hangers are attached to the cross beam by a bolt through connection to ensure high durability.



The rope of the pendulum swing is made of polypropylene (PP) rope in Coconut style with a square shape of 14x14cm. The ends of the Coconut rope are closed by a steel clamps and sealed by a glued-on shrinkable tubing. The last 10cm of the rope ends are cut open to make a tassel with bumper function to fulfill global safety requirements.



The chain/ropes are attached to the Coconut rope by KOMPAN swivel bushings made of stainless steel with bronze bearings. The swivels have an outside cover of black PUR. The usage of side mounted swivels provides frictionless movement, eliminates fingers and feet entrapments and enlarges the standing surface on top of the rope.

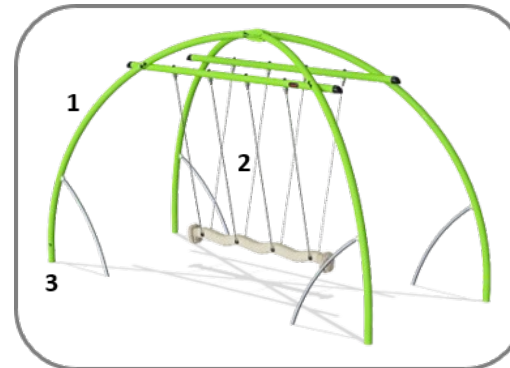

The Cocowave pendulum swing is available in multiple options: Galvanised steel with optional powder coated top finish in lime green colour, Rope or stainless steel chain suspensions, In-ground or surface anchoring.

Item no. M98401-1011

## Installation Information

Max. fall height	179 cm
Safety surfacing area	22.9 m <sup>2</sup>
Total installation time	9.6 hours
Excavation volume	2.08 m <sup>3</sup>
Concrete volume	1.12 m <sup>3</sup>
Footing depth (standard)	100 cm
Shipment weight	620 kg
Anchoring options	In-ground ✓ Surface ✓

## Warranty Information

Hot dip galvanised steel	Lifetime
Chains	10 years
Ropes & nets	10 years
Movable parts	2 years
Spare parts guaranteed	10 years



# Sustainability Data

M984



## Cradle to Gate A1-A3

### Total CO<sub>2</sub> emission

### CO<sub>2</sub>e/kg

### Recycled material

kg CO<sub>2</sub>e

kg CO<sub>2</sub>e/kg

%

**M98401-1011**

2,002.93

5.12

43.70

The overall framework applied for these factors is the Environmental Product Declaration (EPD), which quantifies "environmental information on the life cycle of a product and enable comparisons between products fulfilling the same function" (ISO, 2006). This follows the structure and applies a Life-Cycle Assessment approach to the entire Product stage from raw material through manufacturing (A1-A3))



## Independent review certificate

Kompan A/S  
C. F. Tietgens Blvd. 32C, 5220 Odense SØ

Bureau Veritas hereby attests that the CO<sub>2</sub>e-calculations (covering materials, processing, waste and transport) done by Kompan for "Freestanding Play Equipment", meet the requirements set by the listed standard.

Kompan A/S uses a selection of EPDs and emission factors from the Life Cycle Assessment database Ecoinvent 3.11. These values are reported as kg CO<sub>2</sub>e, with all other impact categories excluded in line with the scope of ISO 14067:2018. The emission factors cover, material use, manufacturing processes, transport to Kompan, and electricity used during manufacturing. The presented emissions fall under GHG Protocol scope 3 emissions. Scope 1 and 2 are not presented. Scope 3 emissions include emission sources in the upstream value chain of a company, downstream emissions are excluded in this analysis.

Method: ISO 14067:2018 using GHG protocol guidance documents, reported as kg CO<sub>2</sub>e.

### Object

The verification has been done on the one pager "KSW92011-0910" version: 27-10-2025. The supporting documentation "KOMPAN data\_updated emissions factors\_2025\_V2" and "Emissions factors, EPD's and ecoinvent 3.11\_2025" was also reviewed and approved.

### Declaration

The verification has been completed as a critical review with a limited assurance. I hereby confirm that nothing has come to the reviewer's attention which would lead to conclude that the study does not give an accurate depiction or isn't completed following method of the CO<sub>2</sub>e calculation, the requirements of ISO 14067:2018, and 14071:2024, in the above referenced documentation.

**Note:** This verification only covers calculation elements according to method described in ISO 14067:2018 and may not be seen as a Life Cycle Assessment according to ISO 14067:2018.

**Ref.:** Kompan\_Verification report 2025, 28-10-2025

**Date of certificate:** 29-10-2025

**Expire date:** 29-10-2027

**Verified by:** Julie Marie Vejsgaard Larsen, Environmental Auditor

**Signature:**

# Giant CocoWave Swing

M984

\* Max fall height | \*\* Total height | \*\*\* Safety surfacing area

\* Max fall height | \*\* Total height

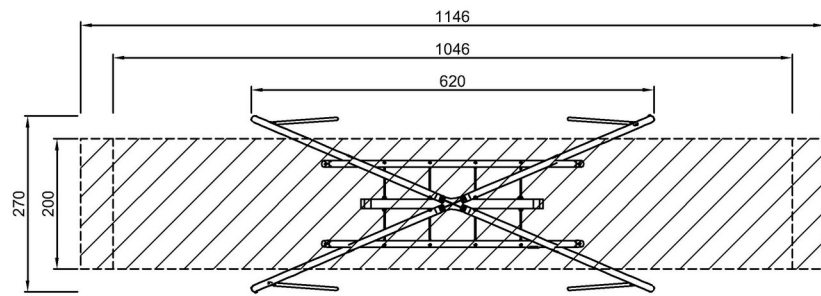

M98401  
\*179cm  
\*\*363cm  
\*\*\*22.9m<sup>2</sup>

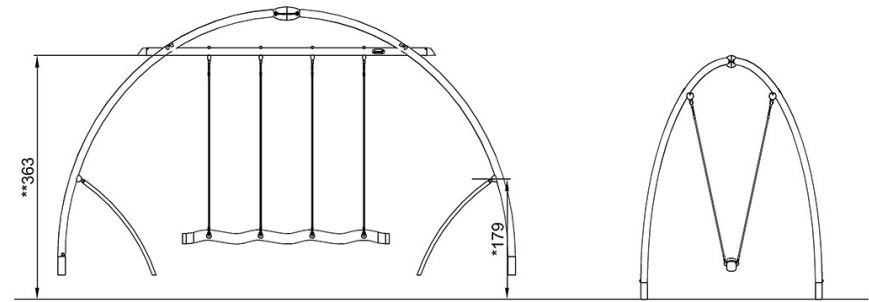

M98401

[Click to see TOP VIEW](#)

[Click to see SIDE VIEW](#)