

Double Tower with Fireman's Pole

KPW201301

KOMPANI



Item no. KPW201301-0901	
General Product Information	
Dimensions LxWxH	384x309x322 cm
Age group	2+
Play capacity (users)	14
Colour options	●

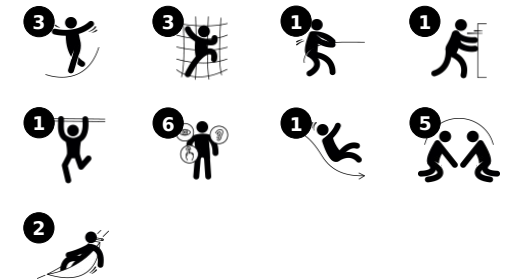

This classic play unit with the vibrant colours attracts children again and again. The tall rock climber, the slide, the wackler bridge and the tall climbing net all create a play variety that makes children want to come back again and again. The play activities, apart from being great fun, train the child's motor skills as well

as muscles. When doing somersaults on the somersault bar, the child trains its sense of space and balance, both mandatory when building up life skills such as judging distances. The see-through wackler bridge adds thrill, as the child can sense the height while passing. The big net has smaller as well as bigger

meshes, facilitating climbing up and climbing through. The slide provides a fun exit, and the fireman's pole provides a dare devil ride. All in all, it's play with a purpose. Enjoyment, fun and build-up of life skills, all in one.



Double Tower with Fireman's Pole

KPW201301

KOMPANI®



Somersault bar

Physical: develop balance and core when hanging from knees. Arm, leg and core muscles are developed when climbing up, somersaulting around. Balance and spatial awareness are strengthened. **Social-Emotional:** meeting, socializing and turn-taking when climbing up and down via bar.



Rock climber

Physical: supports cross coordination and leg, arm and hand strength. **Social-Emotional:** the inclination makes climbing feel secure, especially for younger children.



Climbing net

Physical: children develop cross-body coordination and muscle strength when climbing. The big meshes allow for climbing and crawling through, supporting proprioception and spatial awareness. **Social-Emotional:** the big meshes allow for more children to sit together and talk.



Pipe ladder

Physical: cross coordination and eye-hand coordination are supported when children climb the ladder. The climbing also supports leg and arm muscles. **Social-Emotional:** learning about turn taking and cooperation.



Wackler bridge

Physical: sense of balance and space, and training of posture. Important for being able to sit still. **Social-Emotional:** cooperation, turn-taking and friendly competition on the plates.



Slide

Physical: sliding develops spatial awareness and a sense of balance. Furthermore, the core muscles are trained when sitting upright going down. **Social-Emotional:** empathy stimulated by turn-taking. **Cognitive:** young children develop their understanding of space, speed and distances when sliding down quickly.

Double Tower with Fireman's Pole

KPW201301



Panels of FSC®-certified (FSC®C004450) pine wood with pressure-impregnated base treatment. Vertical boards and top ends are protected by a unique aluminium profile for high outdoor durability.

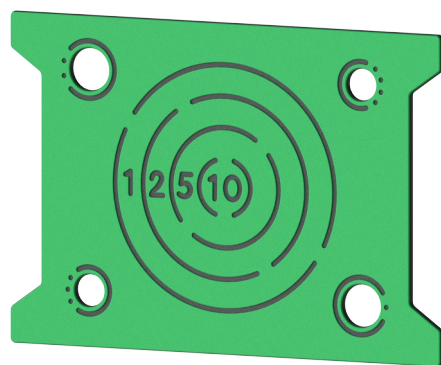

Panels of 19mm EcoCore™. EcoCore™ is a highly durable, eco friendly material, which is not only recyclable after use, but also consists of material produced from +95% recycled post consumer material from food packing waste.



Roof of FSC®-certified (FSC®C004450) pine wood with pressure-impregnated base treatment.

Item no. KPW201301-0901	
Installation Information	
Max. fall height	118 cm
Safety surfacing area	33.5 m ²
Total installation time	14.1 hours
Excavation volume	1.46 m ³
Concrete volume	0.00 m ³
Footing depth (standard)	90 cm
Shipment weight	454 kg
Anchoring options	In-ground ✓ Surface ✓
Warranty Information	
EcoCore HDPE	Lifetime
Aluminum	15 years
Pinewood	10 years
Ropes & nets	10 years
Spare parts guaranteed	10 years



The main tower posts are available in two types of material: European pine wood posts, pressure impregnated Class 3 with Tanalith E3475 according to EN335 (Equivalent to NTR Class AB). Aluminum post t=2mm with anodized surface treatment. Base material EN AW-6060 T66.

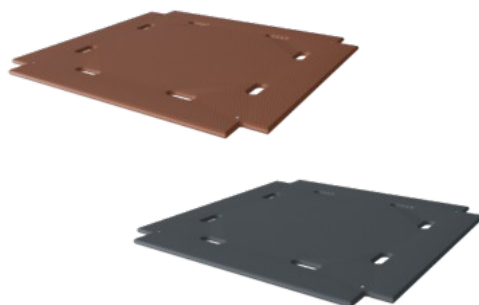

Floors and panel activities are available in two types of material: Waterproof plywood decks, thickness 16mm from pine and alder wood with anti-slip film on both sides. High Pressure Laminate HPL thickness 17.8mm with slip-resistant surface texture according to EN 438-6.



The slides can be chosen in six different colors and three materials: Straight or curved one-piece molded PE slides, made from 33% recycled post-consumer materials in different colours. Combined EcoCore™ sides and stainless-steel. Full stainless steel in one piece design for more vandalism proof solutions.

EN 1176
compliant

Sustainability Data

KPW201301



Cradle to Gate A1-A3

Total CO₂ emission

CO₂e/kg

Recycled material

kg CO₂e

kg CO₂e/kg

%

KPW201301-0901

834.90

2.46

25.80

The overall framework applied for these factors is the Environmental Product Declaration (EPD), which quantifies "environmental information on the life cycle of a product and enable comparisons between products fulfilling the same function" (ISO, 2006). This follows the structure and applies a Life-Cycle Assessment approach to the entire Product stage from raw material through manufacturing (A1-A3))



Independent review certificate

Kompan A/S
C. F. Tietgens Blvd. 32C, 5220 Odense SØ

Bureau Veritas hereby attests that the CO₂e-calculations (covering materials, processing, waste and transport) done by Kompan for "Nature Play", meet the requirements set by the listed standard.

Kompan A/S uses a selection of EPDs and emission factors from the Life Cycle Assessment database Ecoinvent 3.11. These values are reported as kg CO₂e, with all other impact categories excluded in line with the scope of ISO 14067:2018. The emission factors cover, material use, manufacturing processes, transport to Kompan, and electricity used during manufacturing. The presented emissions fall under GHG Protocol scope 3 emissions. Scope 1 and 2 are not presented. Scope 3 emissions include emission sources in the upstream value chain of a company, downstream emissions are excluded in this analysis.

Method: ISO 14067:2018 using GHG protocol guidance documents, reported as kg CO₂e.

Object

The verification has been done on the one pager "NRO40901-0601" version: 27-10-2025. The supporting documentation "KOMPAN data_updated emissions factors_2025_V2" and "Emissions factors, EPD's and ecoinvent 3.11_2025" was also reviewed and approved.

Declaration

The verification has been completed as a critical review with a limited assurance. I hereby confirm that nothing has come to the reviewer's attention which would lead to conclude that the study does not give an accurate depiction or isn't completed following method of the CO₂e calculation, the requirements of ISO 14067:2018, and 14071:2024, in the above referenced documentation.

Note: This verification only covers calculation elements according to method described in ISO 14067:2018 and may not be seen as a Life Cycle Assessment according to ISO 14067:2018.

Ref.: Kompan_Verification report 2025, 28-10-2025

Date of certificate: 29-10-2025

Expire date: 29-10-2027

Verified by: Julie Marie Vejsgaard Larsen, Environmental Auditor

Signature:

Double Tower with Fireman's Pole

KPW201301

* Max fall height | ** Total height | *** Safety surfacing area

* Max fall height | ** Total height

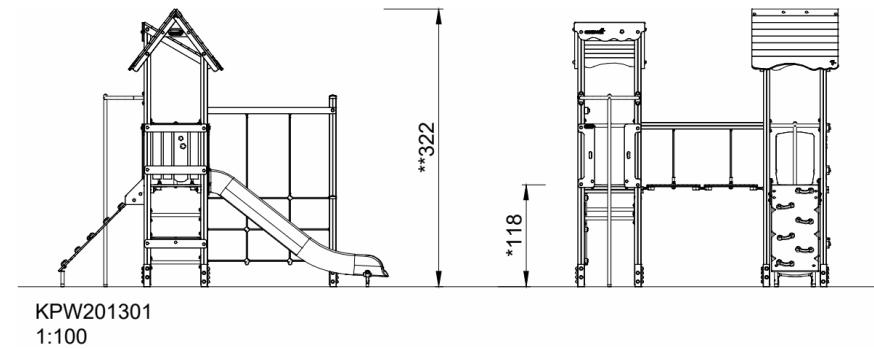
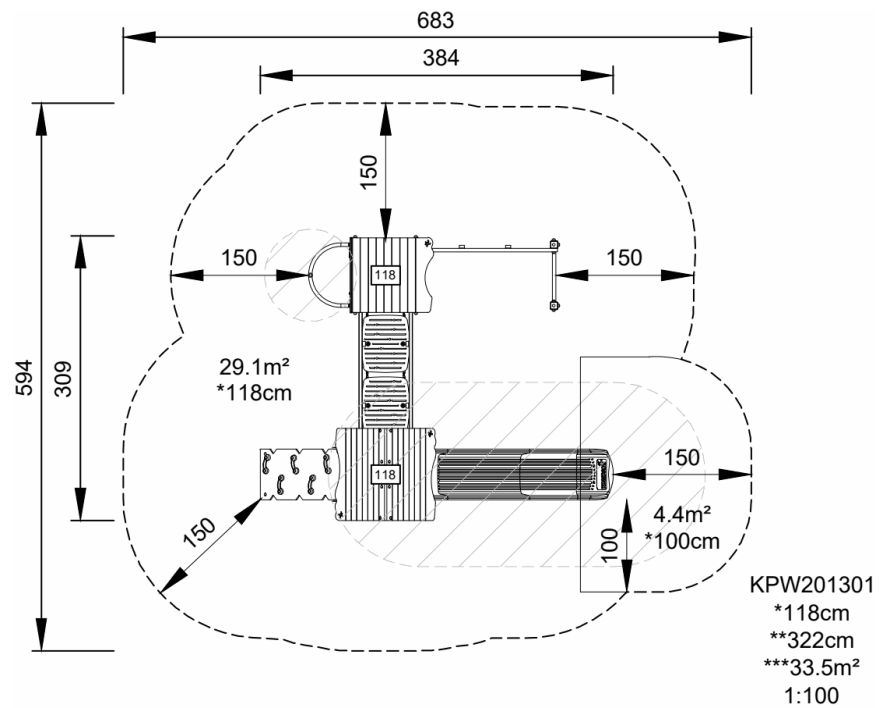

[Click to see TOP VIEW](#)

[Click to see SIDE VIEW](#)